

4

3

2

1

Please Approve this Drawing

Date	
Signature	

REVISIONS				
LTR	DESCRIPTION	DATE	APPROVED	NOTE
	INITIAL RELEASE	06/14/'13		
△				
△				
△				

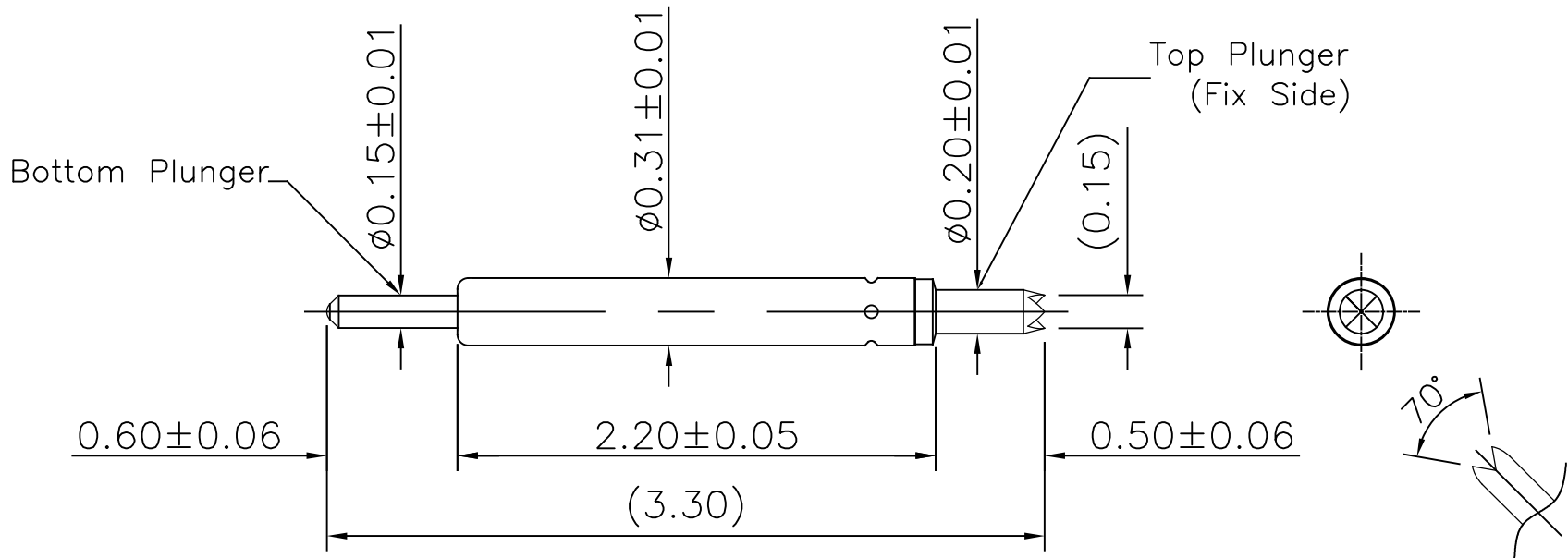

Notes :

1.Materials and Finishes

- Top Plunger : SK4 alloy with gold plating
- Barrel: PhBz alloy with gold plating
- Spring : SWP with flash Au
- Bottom Plunger : BeCu alloy with gold plating

2.Mechanical

- recommended travel : 0.40 mm
- full travel : 0.55 mm
- Spring force : 10 g at initial travel
- Spring force : 25 g \pm 20% at recommended travel
- Spring force : 35 g \pm 20% at full travel

3.Durability :

- Mechanical life 200K cycles(minimum) at recommended travel

DRAWN	江倉如	SCALE: 40 / 1	中國探針股份有限公司 C.C.P. CONTACT PROBES CO.,LTD.								
CHECKED		SHEET: 1 OF 1	TITLE. $\phi 0.31 * \phi 0.20 * 3.30 \text{mm}$								
APPROVED		DATE: 01/07/'14	<table border="1"> <tr> <td>SIZE</td> <td rowspan="2"> </td> <td rowspan="2">DRAWING NO.</td> <td rowspan="2">REV.</td> </tr> <tr> <td>A4</td> <td>PE3-031EF21-02A0</td> <td>00</td> </tr> </table>		SIZE		DRAWING NO.	REV.	A4	PE3-031EF21-02A0	00
SIZE		DRAWING NO.	REV.								
A4				PE3-031EF21-02A0	00						
<small>DIMENSIONS ARE IN MILLIMETERS TOLERANCES ARE: DECIMALS X .25 ± .05 X.X ± .15 ± 3.0° X.XX ± .10 ± 2.0°</small>		<small>THE INFORMATION AND DESIGN DISCLOSED HEREIN WAS ORIGINATED BY AND IS THE PROPERTY OF C.C.P. CONTACT PROBES CO.,LTD. C.C.P. CONTACT PROBES CO.,LTD. RESERVES ALL PATENT, PROPRIETARY DESIGN, MANUFACTURING, REPRODUCTION, USE AND SALES RIGHTS THEREOF, AND TO ANY ARTICLE DISCLOSED HEREIN EXCEPT TO THE EXTENT RIGHTS ARE EXPRESSLY GRANTED TO OTHERS. THE FOREGOING DOES NOT APPLY TO VENDOR PROPRIETARY RIGHTS.</small>									
FILE PATH:											

4

3

2

1

1