

Please Approve this Drawing

Date	
Signature	

REVISIONS(修正)			
NO. (序号)	DESCRIPTION(描述)	ECN NO.(变更号)	DATE(日期)
	INITIAL RELEASE	ECN-2201505021	2015.05.14

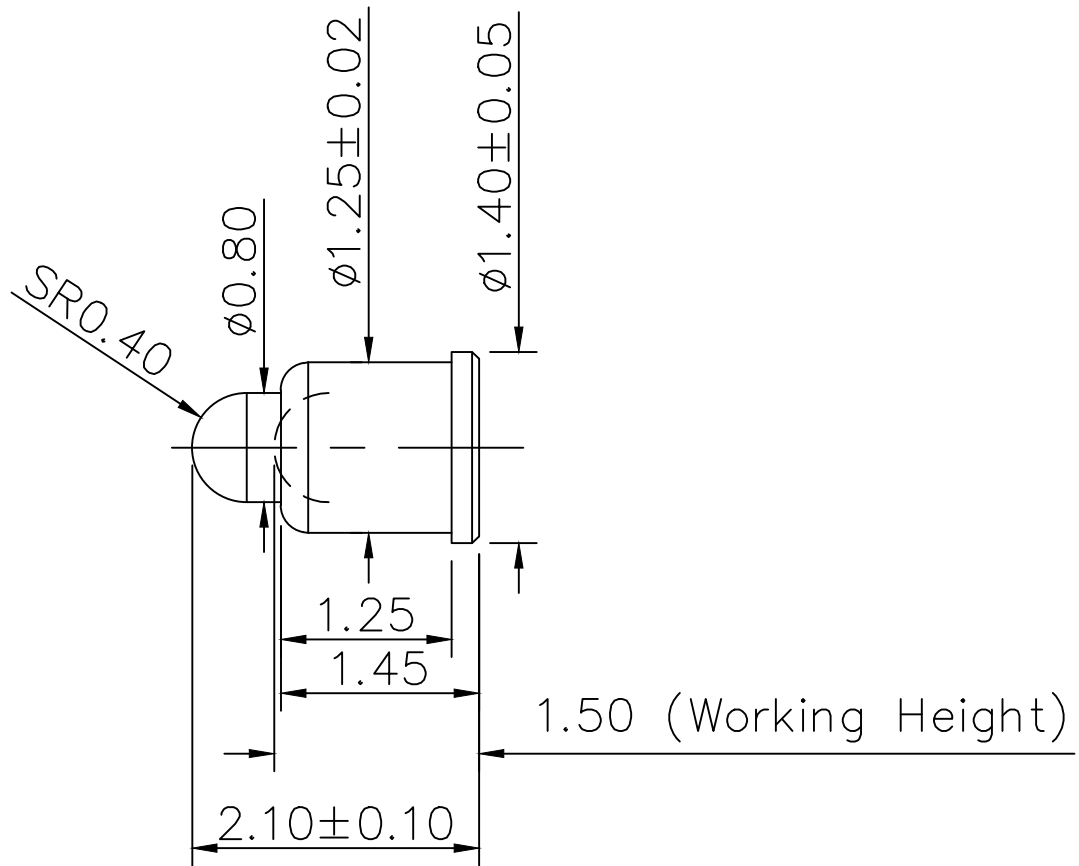

- NOTE;
- Material
 - Plunger: Brass C3604
 - Barrel: Brass C3604
 - Spring :SUS304
 - Plating
 - Plunger: 10 micro-inch minimum Au over 50~100 micro-inch nickel
 - Barrel: 10 micro-inch minimum Au over 50~100 micro-inch nickel
 - Electrical
 - Rated current & voltage: DC 12V; 1A Max.
 - Contact resistance: 100 mohm maximum at working height(quiescence)
 - Mechanical
 - Spring force: $100g \pm 20\%$ at working height
 - Durability: 10,000 cycles(minimum)
 - To ensure the best usage, please operate it based on the working height. Based on the engineering drawings, shall not exceed the maximum allowed compression
 - Harmful material control please follow DOC. NO. "DQ03050"

DRAWN (设计)	杨茜	SCALE (比例)	18 : 1	UNIT (单位)	mm	DRAWING NO. (图号)	H199M2-R
CHECKED (确认)		SHEET (页数)	1 of 1	PROJECT (视图)		TITLE (品名)	POGO PIN
APPROVED (核准)		DATE (日期)	2015.05.14	VER. (版本)	A.0		
THE UNMARKED TOLERANCE ARE AS BELOW : (未标记的公差)				C.C.P. (DG) CONTACT PROBES CO.,LTD. 东莞中探探针有限公司			
LENGTH (尺寸)		ANGLE (角度)					
0~6.0	±0.05mm	0.	±2.0°				
>6~30	±0.10mm	0.0	±1.0°	The information in this document is property of C.C.P company and should not be copied or reproduced in any other way, without written permission.			
>30~120	±0.15mm	0.00	±0.50°				