

Please Approve this Drawing

Date	
Signature	

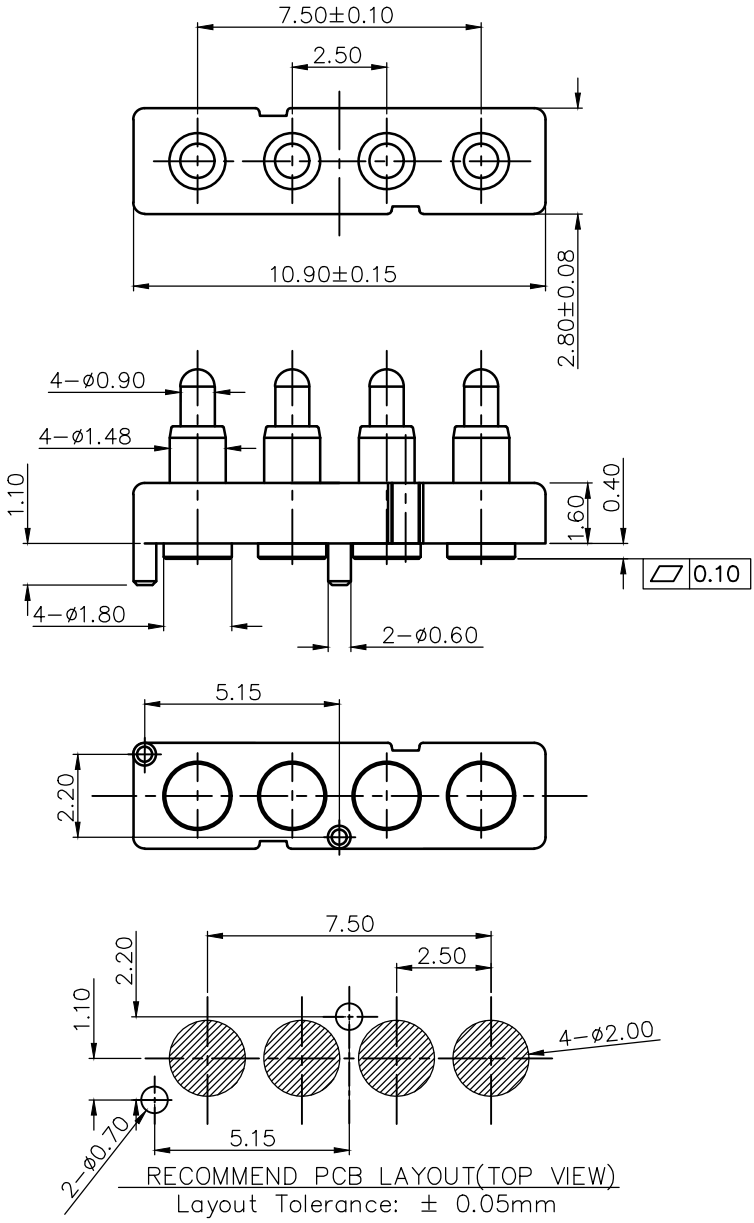

REVISIONS (修正)			
NO. (序号)	DESCRIPTION(描述)	ECN NO.(变更号)	DATE(日期)
A.0	NEW RELEASE	ECN-2201511049	2015.11.16
A.1	弹簧材质由SWP修改为SUS301	ECN-2201711007	2017.11.07

- NOTES:
- Materials:
    - .Housing&CAP: HTN UL94V-0
    - .Plunger: brass
    - .Barrel: brass
    - .Spring: SUS301
  - Plating:
    - .Plunger: 10 micro-inch minimum Au over 50~100 micro-inch nickel.
    - .Barrel : 10 micro-inch minimum Au over 50~100 micro-inch nickel.
  - Electrical:
    - .Rated current & voltage: DC12V, 2A Max.
    - .Contact resistance: 50 mohm maximum at working height(quiescence)
  - Mechanical:
    - .Normal force: 90±20g at Normal working height
    - .Durability: 12,000 cycles(minimum)
  - When the current is greater than 1A then need to increase the time delaycircuit(3 second)
  - To ensure the best usage,please operate it based on the working height
    - .Based on the engineering drawings,shall not exceed the maximum allowed compression
  - Harmful material control please follow DOC. NO. "DQ03050"

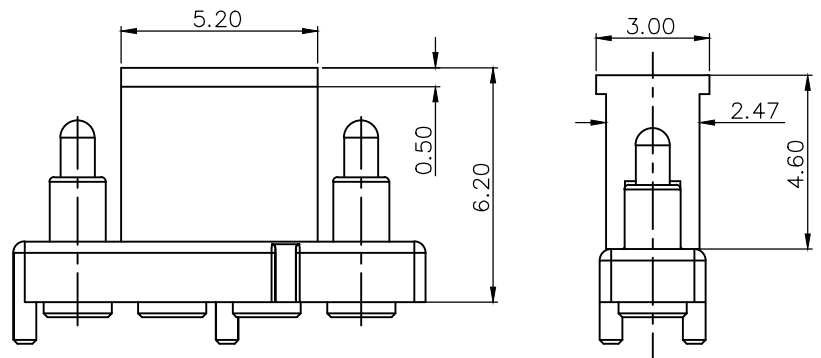

DRAWN (设计)	Wei Yang	SCALE (比例)	10 : 1	UNIT (单位)	mm	DRAWING NO. (图号)	P2808MF01-04D250MR
CHECKED (确认)		SHEET (页数)	1 of 1	PROJECT (视图)		TITLE (品名)	Pogo pin Conn.
APPROVED (核准)		DATE (日期)	2017.11.07	VER. (版本)	A.1		
THE UNMARKED TOLERANCE ARE AS BELOW : (未标记的公差) LENGTH (尺寸)				ANGLE (角度)			
0~6.0	±0.05mm	0.0	±2.0°				
>6~30	±0.10mm	0.0	±1.0°				
>30~120	±0.15mm	0.00	±0.50°				
				C.C.P. (DG) CONTACT PROBES CO.,LTD. 东莞中探探针有限公司			
The information in this document is property of C.C.P company and should not be copied or reproduced in any other way, without written permission.							