

REVISIONS (修正)			
NO. (序号)	DESCRIPTION(描述)	DCN NO.(变更号)	DATE(日期)
A.0	NEW RELEASE	ECN-2201507039	2015.07.24

Please Approve this Drawing	
Date	
Signature	

NOTES:

- Materials:
 - .Cap: HTN+30% G.F UL94V-0 Black color
 - .Plunger: brass
 - .Barrel: brass
 - .Spring: SUS304
- Plating:
 - .Plunger: 10 micro-inch minimum Au over 50~100 micro-inch nickel.
 - .Barrel : 10 micro-inch minimum Au over 50~100 micro-inch nickel.
- Electrical:
 - .Rated current & voltage: DC12V, 1A.
 - .Contact resistance: 50 mohm maximum at working height(quiescence)
- Mechanical:
 - .Normal force:80±20g at Normal working height
 - .Durability: 10,000 cycles(minimum)
- When the current is greater than 1A then need to increase the time delaycircuit(3 second)
- To ensure the best usage,please operate it based on the working height
 - .Based on the engineering drawings,shall not exceed the maximum allowed compression
- Harmful material control please follow DOC. NO. "DQ03050"

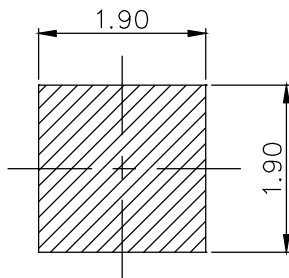
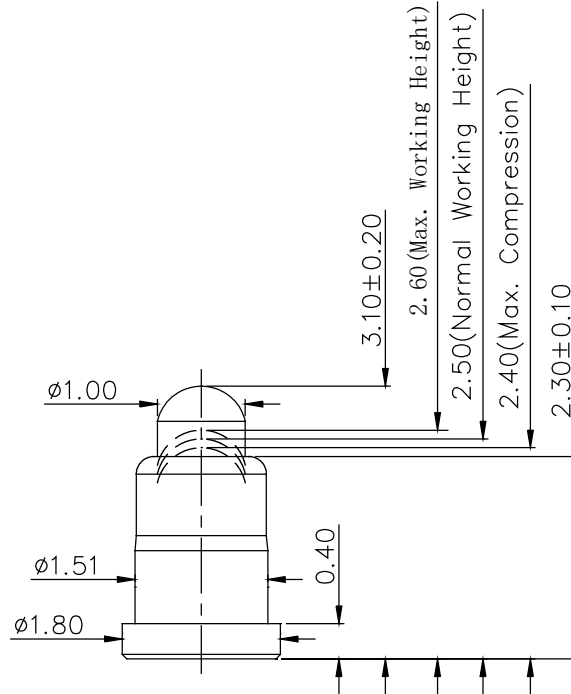

RECOMMEND PCB LAYOUT
Layout Tolerance: ± 0.05mm

DRAWN (设计)	车 澈	SCALE (比例)	10 : 1	UNIT (单位)	mm	DRAWING NO. (图号)	P3198FH01
CHECKED (确认)		SHEET (页数)	1 of 1	PROJECT (视图)		TITLE (品名)	Pogo pin Conn.
APPROVED (核准)		DATE (日期)	2015.07.24	VER. (版本)	A.0		

THE UNMARKED TOLERANCE ARE AS BELOW :
(未标记的公差)

LENGTH (尺寸)		ANGLE (角度)	
0~6.0	±0.05mm	0.	±2.0°
>6~30	±0.10mm	0.0	±1.0°
>30~120	±0.15mm	0.00	±0.50°

C.C.P. (DG) CONTACT PROBES CO.,LTD.
东莞中探探针有限公司

The information in this document is property of C.C.P company and should not be copied or reproduced in any other way, without written permission.