

4

3

2

1

REVISIONS(修正)

NO. (序号)	DESCRIPTION(描述)	ECN NO.(变更号)	DATE(日期)
A.0	INITIAL RELEASE	ECN-2201512013	2015.12.07

NOTES:

- Materials:
  - .Housing: High Temperature Polyester(UL94V-0),Black
  - .Plunger&Barrel: Brass
  - .Spring: SWP
  - .Mylar: polyethylene terephthalate
- Plating:
  - .Plunger :10 micro-inch minimum Au over 50~100 micro-inch Ni.
  - .Barrel :10 micro-inch minimum Au over 50~100 micro-inch Ni.
- Electrical
  - .Rated Current & Voltage : DC 12V ; 1.0A Max
  - .Contact resistance:100 mohm maximum
- Mechanical
  - .Spring Force: 100g±20% at Normal Working Height
  - .Durability:10,000 cycles(minimum)
- .Harmful material control please follow DOC. NO."DQ03050 "

Please Approve this Drawing

Date	
Signature	

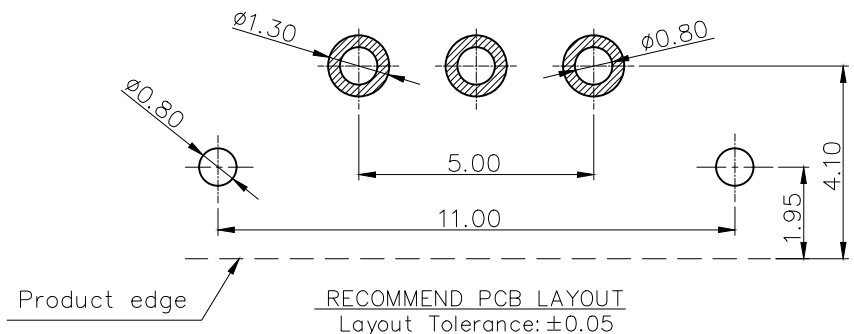
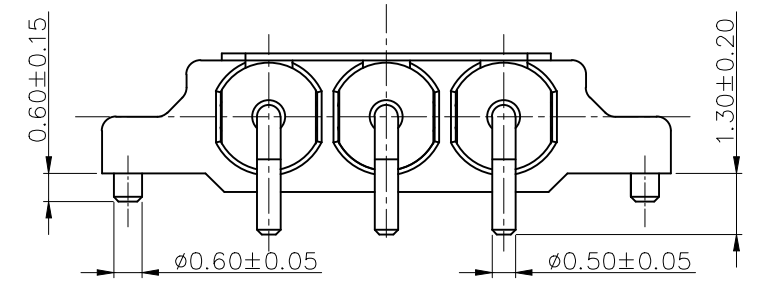
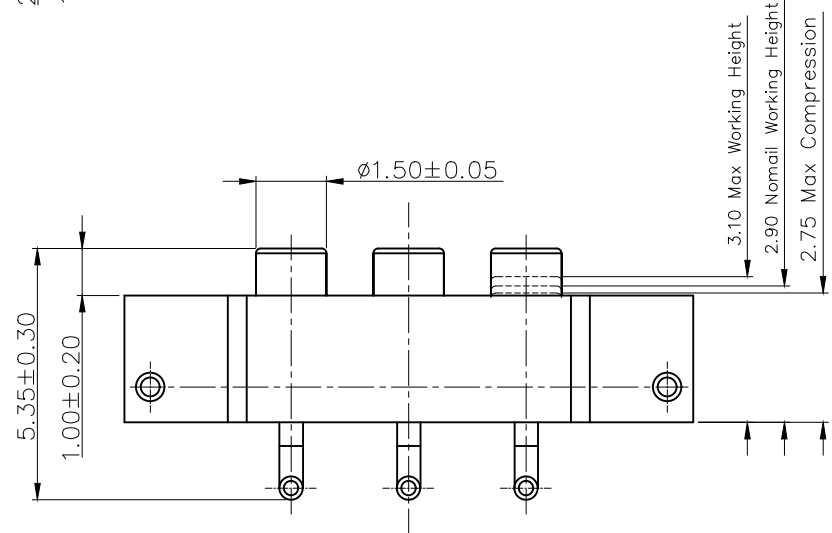
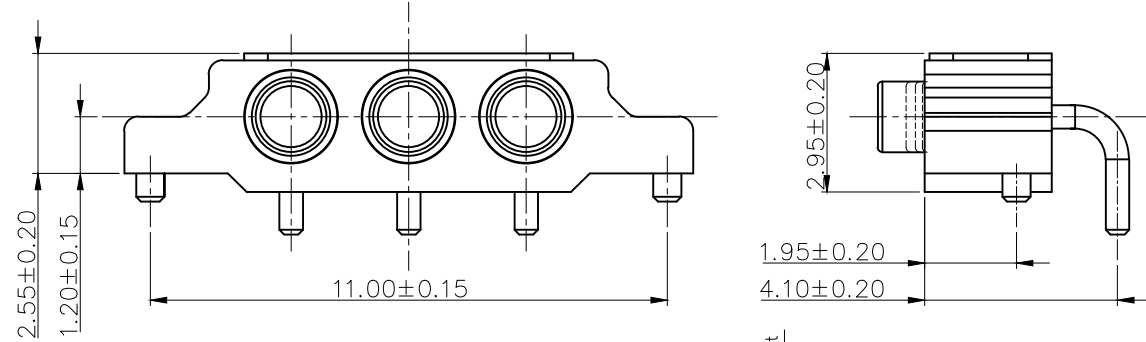
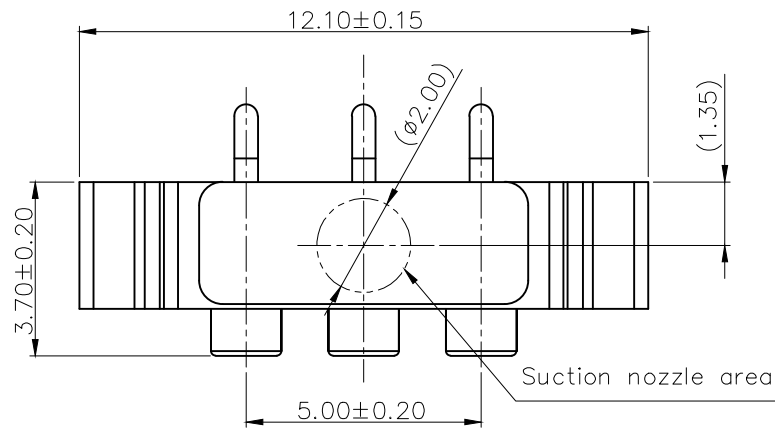

DRAWN (设计)	潘红	SCALE (比例)	5 : 1	UNIT (单位)	mm	DRAWING NO. (图号)	P3309MF01-03R250MR
CHECKED (确认)		SHEET (页数)	1 of 1	PROJECT (视图)		TITLE (品名)	3Pin 2.50mm Pitch Connector
APPROVED (核准)		DATE (日期)	2015.12.07	VER. (版本)	A.0		

THE UNMARKED TOLERANCE ARE AS BELOW :  
 (未标记的公差)  
 LENGTH (尺寸)                      ANGLE (角度)

0~6.0	±0.05mm	0.	±2.0°
>6~30	±0.10mm	0.0	±1.0°
>30~120	±0.15mm	0.00	±0.50°

**C.C.P. (DG) CONTACT PROBES CO.,LTD.**  
**东莞中探探针有限公司**

The information in this document is property of C.C.P company and should not be copied or reproduced in any other way, without written permission.

4

3

4

2

1