

Please Approve this Drawing

Date
Signature

REVISIONS (修正)

NO. (序号)	DESCRIPTION(描述)	ECN NO.(变更号)	DATE(日期)
A.0	NEW RELEASE	ECN-2201511069	2015.11.26
A.1	图面长度尺寸公差由±0.20改为±0.10	ECN-2201805023	2018.05.21

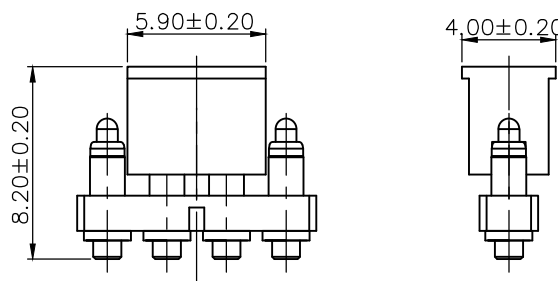
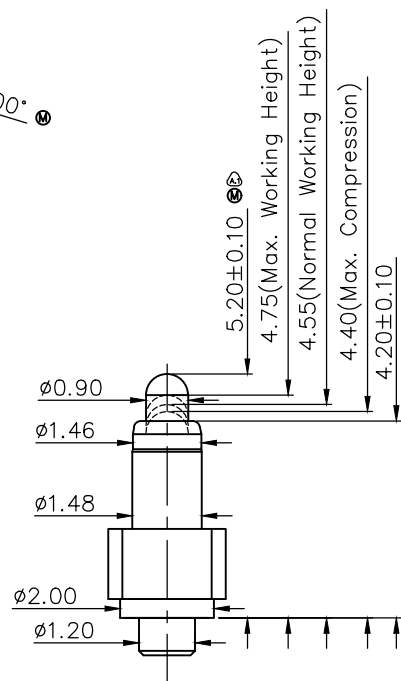
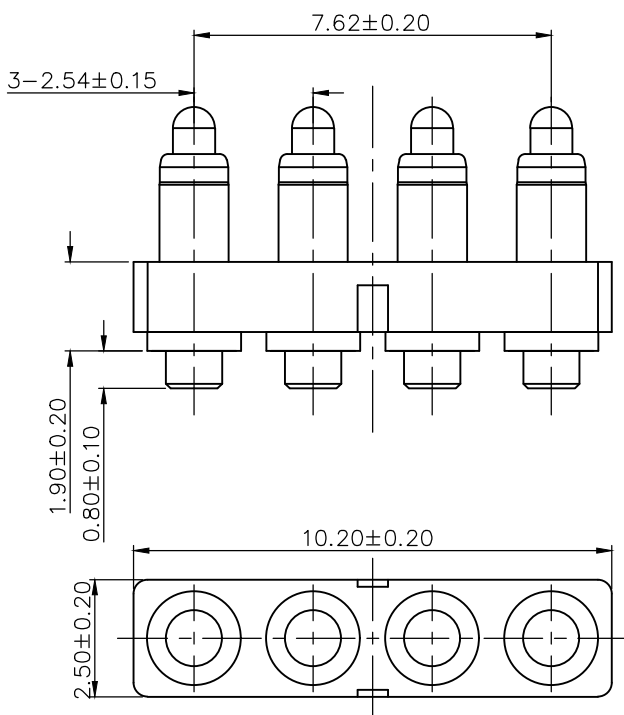
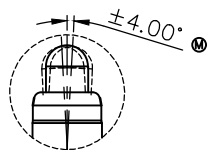

SCALE 1 : 2

NOTES(备注):

- Materials(材质):**
 .Housing(塑胶本体) : PA46 UL94V-0 BLACK
 .CAP(盖子) : HTN+30%GF UL94V-0 BLACK
 .Plunger& Barrel(针轴&内管): Brass (黄铜)
 .Spring(弹簧): SWP (琴钢线)
- Plating(电镀):**
 .Plunger :10 micro-inch minimum Au over 50~100 micro-inch Ni.
 (针轴: 镀镍50~100 micro-inch 后最少镀金10 micro-inch)
 .Barrel :10 micro-inch minimum Au over 50~100 micro-inch Ni.
 (针管: 镀镍50~100 micro-inch 后最少镀金10 micro-inch)
- Electrical(电气特性)**
 .Rated Current & Voltage: DC 12 V ; 1A
 (电压&电流: 直流电12 伏 ; 1 安)
 .Contact Resistance: 50 mohm maximum at Working Height
 (Quiescence)(接触阻抗 在工作高度时最大阻抗50毫欧(静态))
- Mechanical(机械特性)**
 .Spring Force(弹力) :55g±10g at Normal working height
 (在正常工作高度的弹力55g±10g)
 .Durability: 10,000 cycles(minimum)(寿命:10,000 次(最少))
- When the current is greater than 1A than need to increase the time delaycircuit(3 second)**
 (当电流超过1安培时, 需增加延迟时间(3秒))
- To ensure the best usage, please operate it based on the working Height.**
 (为了确保产品最佳性能, 请在工作高度范围内使用)
 .Based on the Engineering Drawings, shall not exceed the maximum allowed compression.
 (根据工程图纸, 不得超过允许的最大压缩行程使用)
- Mark is Major Dimension.** (标Ⓜ 为重点管控尺寸)
- Harmful material control please follow DOC. NO. "DQ03050"**
 (有害物质管控请遵循文件NO. "DQ03050")

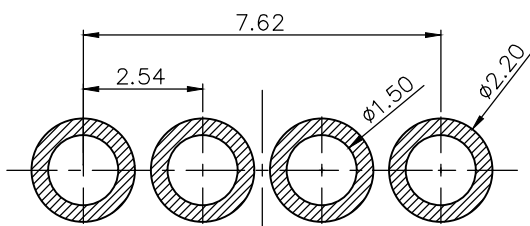

RECOMMEND PCB LAYOUT(TOP VIEW)
Layout Tolerance: ± 0.05mm

DRAW (设计)	麦炜轩	SCALE (比例)	10 : 1	UNIT (单位)	mm	DRAWING NO. (图号)	P3859MP01-04A254MR
COUNTER SIGN (会签)		SHEET (页数)	1 of 1	PROJECT (视图)		MATERIAL (材质)	Seeing notes (见备注)
AUDIT (审核)		DATE (日期)	2018.05.21	VER (版次)	A.1	TITLE (品名)	Pogo pin Conn.
APPROVE (核准)		PLATE (镀层)	Seeing notes(见备注)				

THE UNMARKED TOLERANCE ARE AS BELOW :
(未标记的公差)

LENGTH (尺寸)		ANGLE (角度)	
0~6.0	±0.05mm	0.	±2.0°
>6~30	±0.10mm	0.0	±1.0°
>30~120	±0.15mm	0.00	±0.50°

C.C.P. (DG) CONTACT PROBES CO.,LTD.
东莞中探探针有限公司
The information in this document is property of C.C.P company and should not be copied or reproduced in any other way, without written permission.