

Please Approve this Drawing

Date	
Signature	

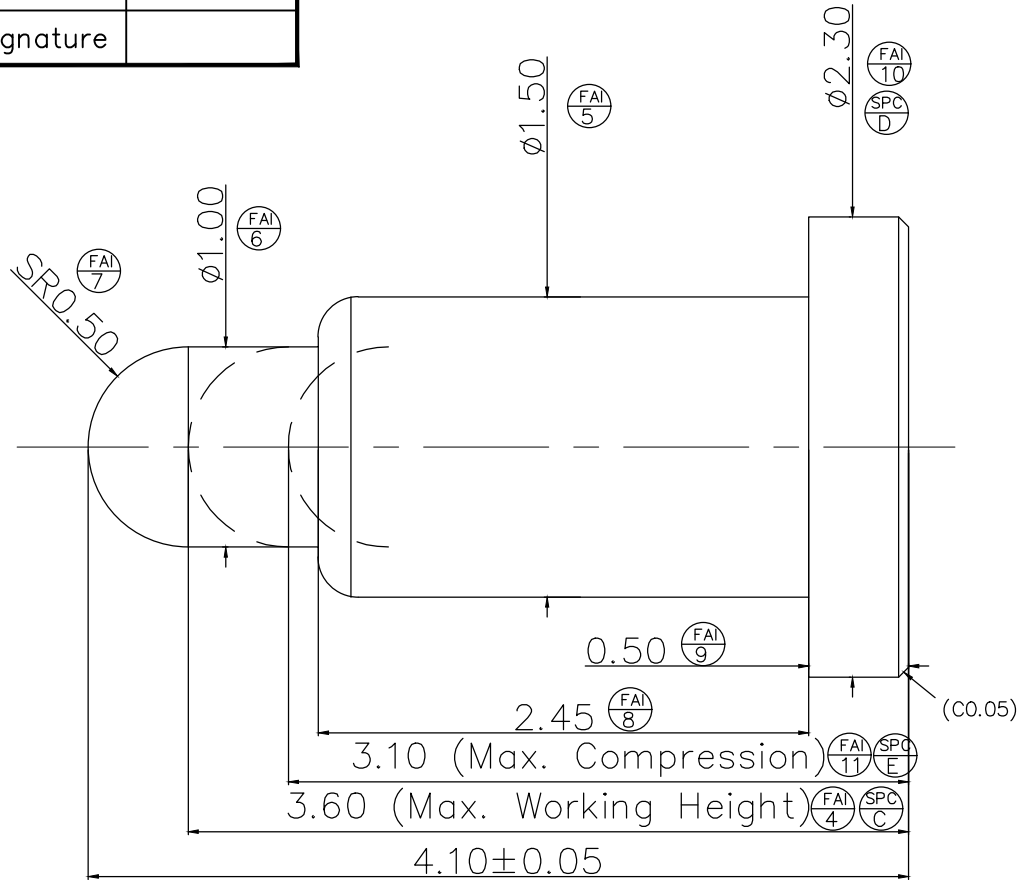

REVISIONS (修正)			
NO. (序号)	DESCRIPTION(描述)	ECN NO.(变更号)	DATE(日期)
A.0	INITIAL RELEASE	ECN-2201605018	2016.05.24

NOTES:

- Materials:
  - .Plunger: brass
  - .Barrel: brass
  - .Spring: SUS
- Plating:
  - .Plunger: 10 micro-inch minimum Pd over 10 micro-inch minimum Au over 40~80 micro-inch CuSnZn.
  - .Barrel : 10 micro-inch minimum Pd over 10 micro-inch minimum Au over 40~80 micro-inch CuSnZn.
- Electrical:
  - .Rated current & voltage: DC12V, 1A.
  - .Contact resistance: 100 mohm maximum at working height(quiescence)
- Mechanical:
  - .Normal force: 80±20g at Normal working height
  - .Durability: 100,000 cycles(minimum)
- To ensure the best usage, please operate it based on the working height
- .Based on the engineering drawings, shall not exceed the maximum allowed compression
- ◆ Mark is the customer's IQC major examine dimension.
- Harmful material control please follow DOC. NO. "DQ03050"

DRAW (设计)	linyushou	SCALE (比例)	10 : 1	UNIT (单位)	mm	DRAWING NO. (图号)	P5067FP01-R		
CHECK (校对)		SHEET (页数)	1 of 1	PROJECT (视图)		MATERIAL (材质)	Seeing notes (见备注)		
AUDIT (审核)		COUNTER SIGN (会签)		DATE (日期)	2016.05.24	REV	A.0		
APPROVE (核准)		PLATE (镀层)		Seeing notes(见备注)		TITLE (品名)	Pogo pin		

THE UNMARKED TOLERANCE ARE AS BELOW :  
(未标记的公差)

LENGTH (尺寸)		ANGLE (角度)	
0~6.0	±0.05mm	0.	±2.0°
>6~30	±0.10mm	0.0	±1.0°
>30~120	±0.15mm	0.00	±0.50°

C.C.P. (DG) CONTACT PROBES CO.,LTD.  
东莞中探探针有限公司

The information in this document is property of C.C.P company and should not be copied or reproduced in any other way, without written permission.