

Please Approve this Drawing

Date	
Signature	

REVISIONS (修正)			
NO. (序号)	DESCRIPTION(描述)	DCN NO.(变更号)	DATE(日期)
D.0	NEW RELEASE	DCN-201805081	2018.05.14

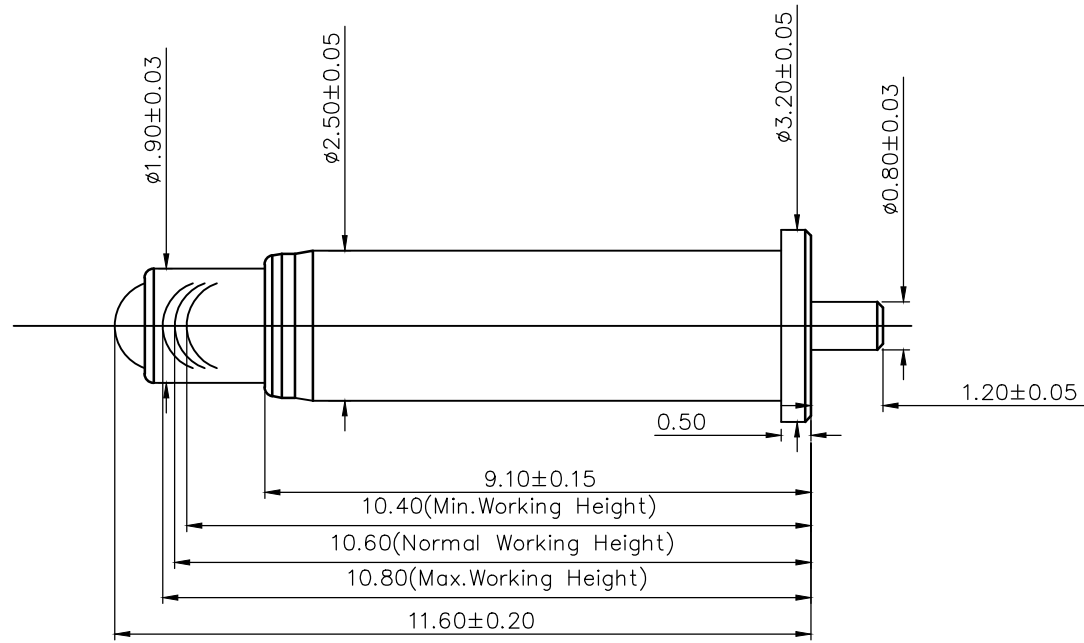

NOTES:

- Materials:
 - .Plunger1&2: brass
 - .Barrel: brass
 - .Spring: SUS
 - .Ball: brass
- Plating:
 - .Plunger1&2: 10 micro-inch minimum Au over 50~120 micro-inch nickel.
 - .Barrel : 10 micro-inch minimum Au over 50~120 micro-inch nickel.
 - .Ball: 5 microinch minimum Pd over 30 microinch minimum PdNi over 40~80 microinch Ni
- Electrical:
 - .Rated current & voltage: DC12V, 2A.
 - .Contact resistance: 50 mohm maximum at working height(quiescence)
- Mechanical:
 - .Normal force: 90g±20g at Normal working height
 - .Durability: 10,000 cycles(minimum)
- To ensure the best usage, please operate it based on the working height
 - .Based on the engineering drawings, shall not exceed the maximum allowed compression
- RoHS & HF complied product

DRAW (设计)	王云	SCALE (比例)	10 : 1	UNIT (单位)	mm	DRAWING NO. (图号)	P6353PP02
COUNTER SIGN (会签)		SHEET (页数)	1 of 1	PROJECT (视图)		MATERIAL (材质)	Seeing notes (见备注)
AUDIT (审核)		DATE (日期)	2018.05.14	VER (版次)	D.0	TITLE (品名)	Pogo pin
APPROVE (核准)		PLATE (镀层)	Seeing notes(见备注)				

THE UNMARKED TOLERANCE ARE AS BELOW :
(未标记的公差)

LENGTH (尺寸)		ANGLE (角度)	
0~6.0	±0.05mm	0.0	±2.0°
>6~30	±0.10mm	0.0	±1.0°
>30~120	±0.15mm	0.00	±0.50°

东莞中探探针有限公司

The information in this document is property of C.C.P company and should not be copied or reproduced in any other way, without written permission.