

4

3

2

1

REVISIONS (修正)

NO. (序号)	DESCRIPTION(描述)	DCN NO.(变更号)	DATE(日期)
A.0	NEW RELEASE	ECN-120120727004	2012.07.27
A.1	Change Package	ECN-2201709035	2017.09.25

NOTES(备注):

1. Materials(材质):

- .CAP(胶盖) : HTN UL94V-0 Black
- .Plunger& Barrel(针轴&内管): Brass C3604 (黄铜C3604)
- .Spring(弹簧): SUS304 不锈钢

2. Plating(电镀):

- .Plunger :10 micro-inch minimum Au over 50~120 micro-inch Ni.
(针轴: 镀镍50~120 micro-inch 后最少镀金10 micro-inch)
- .Barrel :10 micro-inch minimum Au over 50~120 micro-inch Ni.
(针管: 镀镍50~120 micro-inch 后最少镀金10 micro-inch)

3. Electrical(电气特性)

- .Rated Current & Voltage: DC 12 V ; 3A(电压&电流: 直流电12 伏 ; 3安)
- .Contact Resistance: 50 mohm maximum at Working Height
(接触阻抗: 在工作高度时最大阻抗50 毫欧(静态))

4. Mechanical(机械特性)

- .Spring Force(弹力) :150g~200g at 1.3mm Stroke
(在压缩行程1.3mm的弹力150g~200g)
- .Durability: 10,000 cycles(minimum)(寿命:10,000 次(最少))

5 .To ensure the best usage, please operate it based on the working Height.

(为了确保产品最佳性能, 请在工作高度范围内使用)

.Based on the Engineering Drawings, shall not exceed the maximum allowed compression.

(根据工程图纸, 不得超过允许的最大压缩行程使用)

6. Ⓜ Mark is Major Dimension. (标有Ⓜ 为重点管控尺寸)

7.Harmful material control please follow DOC. NO. "DQ03050"
(有害物质管控请遵循文件NO. "DQ03050")

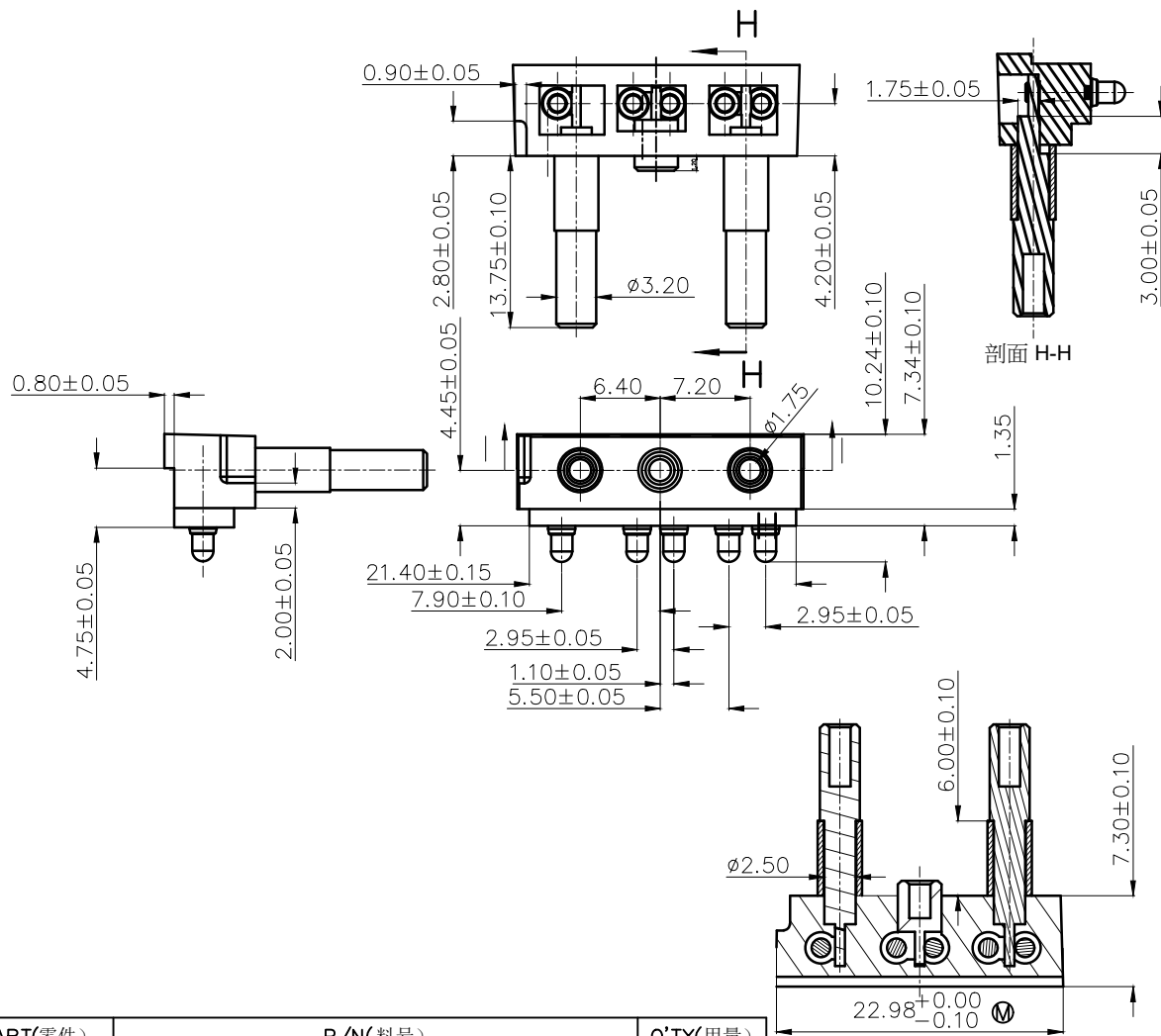

剖面 I-I

PART(零件)	P/N(料号)		Q'TY(用量)
Pogo Pin (N183M0)	Plunger(针轴)	N183P0-A15	5
	Barrel(针管)	N183R0-A15	5
	Spring(弹簧)	N183S0	5
热缩套管	HCS039M0-A01		2
Pin	HCS014P1-A05		2
Pin	HCS015M0-A05		1
Housing(主体)	H05A295-E0		1
Tray(吸塑盘)	H05A295-T0		1
Package(包装)	P848AA01-05295RR		1

DRAW (设计)	陈文明	SCALE (比例)	10 : 1	UNIT (单位)	mm	DRAWING NO. (图号)	P848AA01-05295R
COUNTER SIGN (会签)		SHEET (页数)	1 of 1	PROJECT (视图)		MATERIAL (材质)	Seeing notes (见备注)
AUDIT (审核)		DATE (日期)	2017.09.25	VER (版次)	A.1	TITLE (品名)	Pogo pin Conn.
APPROVE (核准)		PLATE (镀层)	Seeing notes(见备注)				

THE UNMARKED TOLERANCE ARE AS BELOW :
(未标记的公差)

LENGTH (尺寸)		ANGLE (角度)	
0~6.0	±0.05mm	0.	±2.0°
>6~30	±0.10mm	0.0	±1.0°
>30~120	±0.15mm	0.00	±0.50°

C.C.P. (DG) CONTACT PROBES CO.,LTD.
东莞中探探针有限公司

The information in this document is property of C.C.P company and should not be copied or reproduced in any other way, without written permission.