

Please Approve this Drawing.

Date

Signature

REVISIONS

NO.	DESCRIPTION	ECN NO.	DATE
	INITIAL RELEASE	ECN-2201407033	2014.07.10
△			

東莞中探探針有限公司
研發單位
2014.07.14
圖面請妥善保管
版權所有翻印必究

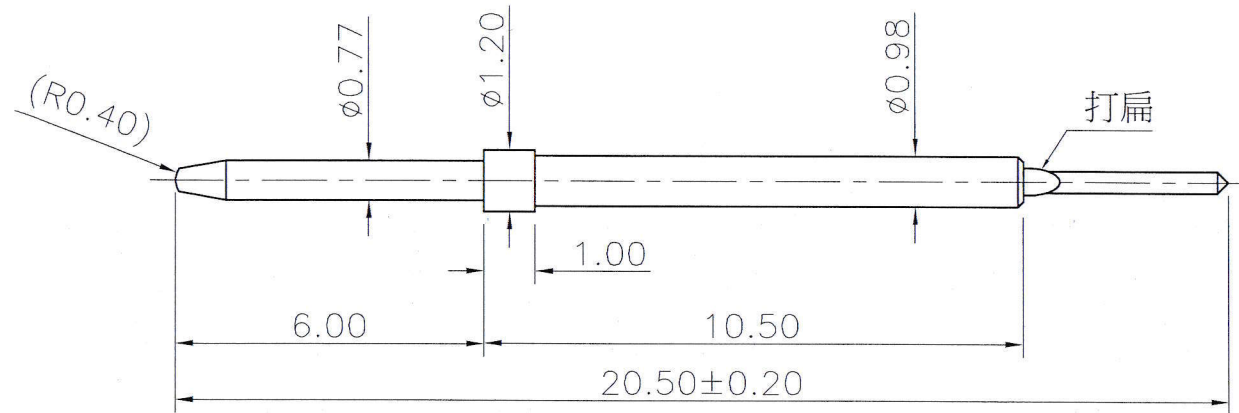

NOTE;

1. Material

Plunger: BeCu Au Plated
Barrel: Brass Ni Plated
Spring: SUS304 Not Au Plated

2. Mechanical

Full stroke: 4.50 mm
Spring Force : $80g \pm 20\%$ at 3.00 mm working stroke
Durability: 100,000 cycles(minimum)

3. Harmful material control please follow DOC. NO."DQ03050"

DRAWN	linyushou	SCALE:	1 : 1	UNIT	mm	DRAWING NO.	S-1D-0510
CHECKED		SHEET:	1 of 1	PROJECT		TITLE. Test Probe	
APPROVED		DATE:	2014.07.10	VER.	A.0		
THE UNMARKED TOLERANCE ARE AS BELOW :						C.C.P. (DG) CONTACT PROBES CO.,LTD.	
LENGTH		ANGLE		东莞中探探針有限公司			
0~6.0	$\pm 0.05\text{mm}$	0.	$\pm 2.0^\circ$	The information in this document is property of C.C.P company and should not be copied or reproduced in any other way, without written permission.			
>6~30	$\pm 0.10\text{mm}$	0.0	$\pm 1.0^\circ$				
>30~120	$\pm 0.15\text{mm}$	0.00	$\pm 0.50^\circ$				