

4

3



2

1

Please Approve this Drawing	
Date	
Signature	

REVISIONS				
LTR	DESCRIPTION	DATE	APPROVED	NOTE
	INITIAL RELEASE	01/11/'17		ECN-106XX
△	Modify 0.70 to 0.80mm	01/19/'17		ECN-106XX
△				
△				

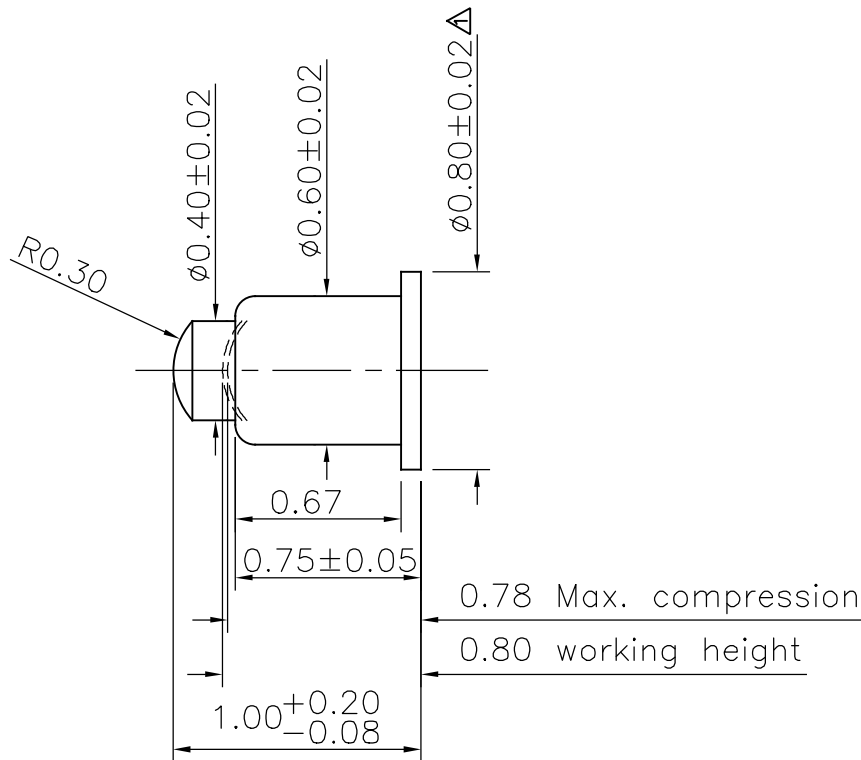

Notes :

1.Materials

- Plunger : Brass alloy
- Barrel : Brass alloy
- Spring : SUS

2.Plating

- Plunger : 10 micro-inch minimum Au over 50~100micro-inch nickel
- Barrel : 10 micro-inch minimum Au over 50~100micro-inch nickel

3.Mechanical

- Spring force : 25 g ± 20% at working height.

DRAWN		SCALE: 25 / 1
CHECKED		SHEET: 1 OF 1
APPROVED		DATE:01/19/'17
DIMENSIONS ARE IN MILLIMETERS TOLERANCES ARE: DECIMALS            ANGLES X    ± .25            ± 5.0° X.X   ± .15           ± 3.0° X.XX ± .10          ± 2.0° UNIT : mm		THE INFORMATION AND DESIGN DISCLOSED HEREIN WAS ORIGINATED BY AND IS THE PROPERTY OF C.C.P. CONTACT PROBES CO.,LTD. C.C.P. CONTACT PROBES CO.,LTD. RESERVES ALL PATENT, PROPRIETARY DESIGN, MANUFACTURING, REPRODUCTION, USE AND SALES RIGHTS THEREOF, AND TO ANY ARTICLE DISCLOSED HEREIN EXCEPT TO THE EXTENT RIGHTS ARE EXPRESSLY GRANTED TO OTHERS. THE FOREGOING DOES NOT APPLY TO VENDOR PROPRIETARY RIGHTS.
FILE PATH:		

中國探針股份有限公司  
C.C.P. CONTACT PROBES CO.,LTD.

TITLE.	ϕ0.40*ϕ0.60*1.00	
	POGO PIN	
SIZE		DRAWING NO.
A4		CS97175M2
		REV.
		01