

Please Approve this Drawing

Date	
Signature	

REVISIONS (修正)			
NO. (序号)	DESCRIPTION(描述)	ECN NO.(变更号)	DATE(日期)
A.0	NEW RELEASE	ECN-2201908014	2020.03.05

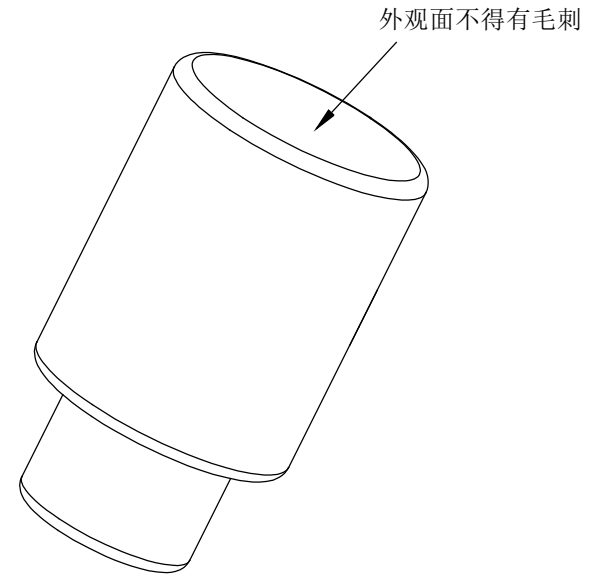
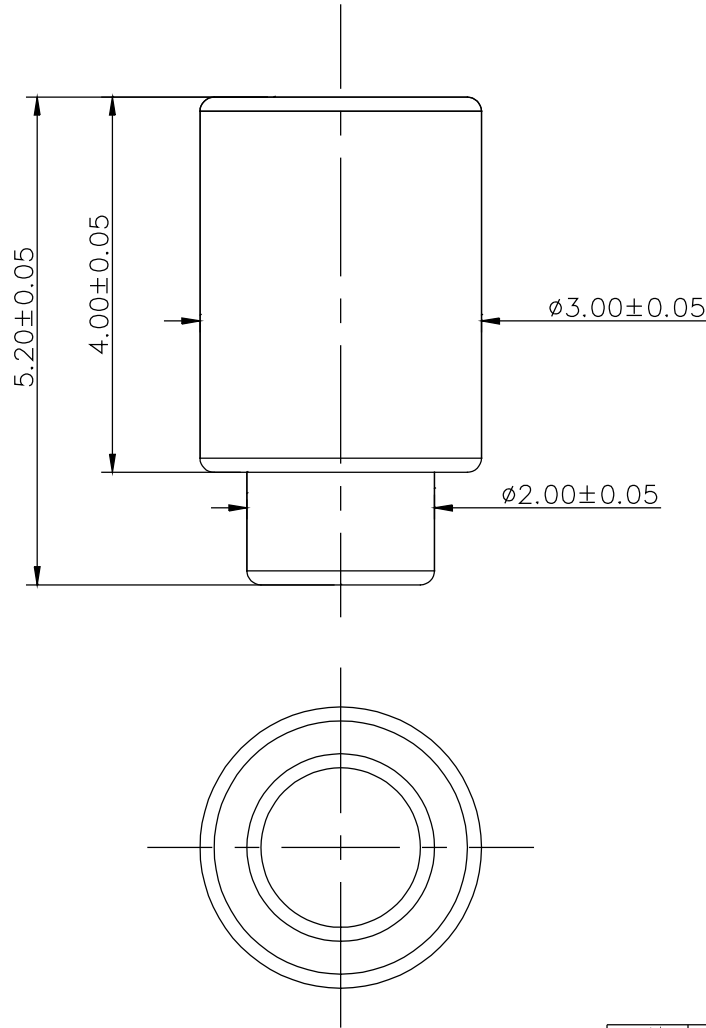

- NOTE;
- Material
Pin: brass
 - Plating
Pin: 10 micro-inch minimum Au over 50~120 micro-inch nickel
 - With burr removal process on the surface, surface roughness is Ra0.4 unless specifically noted.
 - The surface shall not have any bumps, scratches and other undesirable phenomena.
 - RoHS & HF complied product.

DRAW (设计)	黄业沛	SCALE (比例)	10 : 1	UNIT (单位)	mm	DRAWING NO. (图号)	HCS1618SM01-T
COUNTER SIGN (会签)		SHEET (页数)	1 of 1	PROJECT (视图)		MATERIAL (材质)	Seeing notes (见备注)
AUDIT (审核)	黄创国	DATE (日期)	2020.03.05	VER (版次)	A.0	TITLE (品名)	Pin Conn.
APPROVE (核准)	杨增达	PLATE (镀层)	Seeing notes(见备注)				
THE UNMARKED TOLERANCE ARE AS BELOW : (未标记的公差)				C.C.P. (DG) CONTACT PROBES CO.,LTD.			
LENGTH (尺寸)		ANGLE (角度)		东莞中探探针有限公司			
0~6.0	±0.05mm	0.	±2.0°	The information in this document is property of C.C.P company and should not be copied or reproduced in any other way, without written permission.			
>6~30	±0.10mm	0.0	±1.0°				
>30~120	±0.15mm	0.00	±0.50°				