

Please Approve this Drawing	
Date	
Signature	

REVISIONS			
NO.	DESCRIPTION	ECN NO.	DATE
	INITIAL RELEASE		2006.09.11
△	增加滚沟	ECN-2201403011	2014.03.06

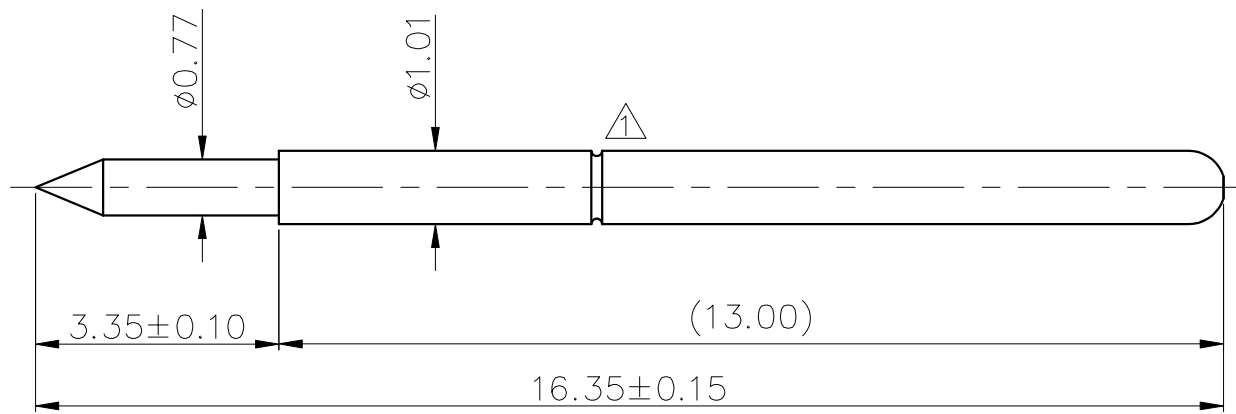

NOTE;

- Material  
Plunger: SK4 Au plated  
Barrel: Brass Au plated  
Spring: SUS304
- Electrical  
Rated current : 3A Max.  
Contact resistance: 100 mohm maximum at working stroke(quiescence)
- Mechanical  
Full stroke: 3.35 mm  
Spring Force : 90g±20% at 2.25 mm working stroke  
Durability: 100,000 cycles(minimum)
- Harmful material control please follow DOC. NO."DQ03050"

DRAWN	linyushou	SCALE:	1 : 1	UNIT	mm	DRAWING NO.	CS86183M
CHECKED		SHEET:	1 of 1	PROJECT		TITLE. Test Probe	
APPROVED		DATE:	2014.03.06	VER.	A.1		
THE UNMARKED TOLERANCE ARE AS BELOW :						C.C.P. (DG) CONTACT PROBES CO.,LTD.	
LENGTH		ANGLE		东莞中探探针有限公司			
0~6.0	±0.05mm	0.	±2.0°	The information in this document is property of C.C.P company and should not be copied or reproduced in any other way, without written permission.			
>6~30	±0.10mm	0.0	±1.0°				
>30~120	±0.15mm	0.00	±0.50°				