

4

3

2

1

Please Approve this Drawing	
Date	
Signature	

REVISIONS (修正)			
NO. (序号)	DESCRIPTION(描述)	DCN NO.(变更号)	DATE(日期)
D.0	NEW RELEASE	DCN-201804019	2018/04/03
D.1	修正图面	DCN-201810031	2019/02/21

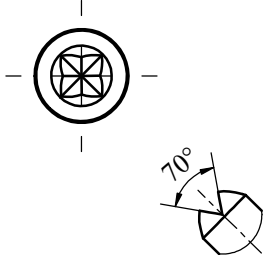
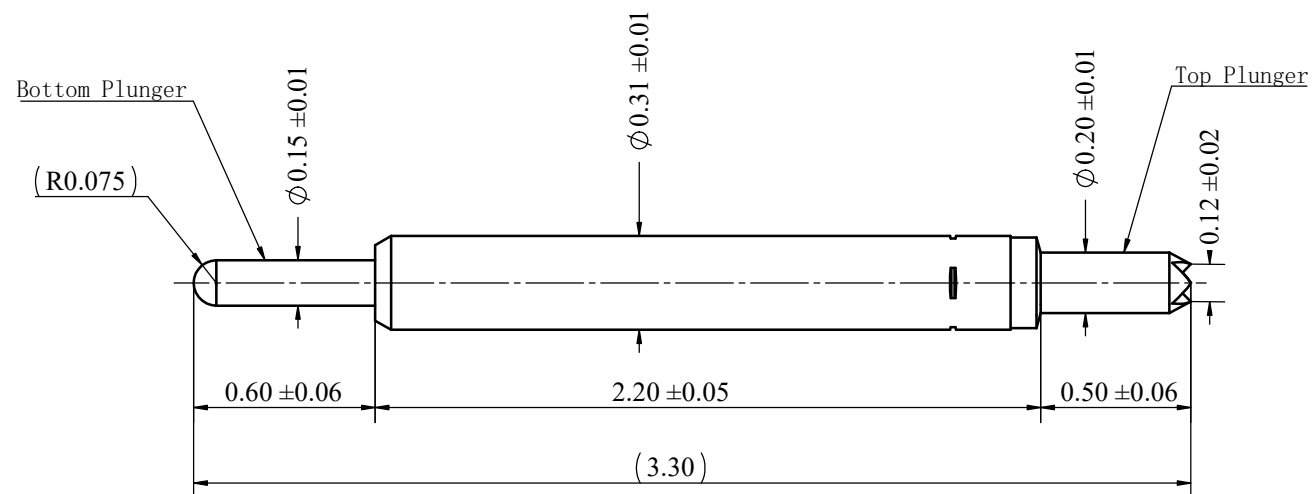
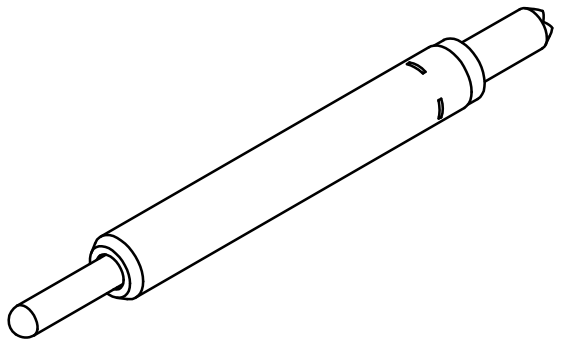

- Notes :
- Materials and Finishes
 - Top Plunger : BeCu alloy with gold plating
 - Barrel : PhBz alloy with gold plating
 - Spring : SWP with gold plating
 - Bottom Plunger : BeCu alloy with gold plating
 - Mechanical
 - Recommended travel : 0.40 mm
 - Full travel : 0.55 mm
 - Spring force : 10 g at initial travel
 - Spring force : 30 g ± 20% at recommended travel
 - Spring force : 40 g ± 20% at full travel
 - Durability :
 - Mechanical life : 200k cycles(minimum) at recommended travel
 - Pointing accuracy : ± 0.05 mm
 - RoHS and HF compliant product.

DRAW (设计)	钟志鹏	SCALE (比例)	40:1	UNIT (单位)	mm	DRAWING NO. (图号)	DE3-031DF21-01A0
COUNTER SIGN (会签)	N/A	SHEET (页数)	1 of 1	PROJECT (视图)		MATERIAL (材质)	NA
AUDIT (审核)	-	DATE (日期)	2019/02/21	VER (版次)	D.1	TITLE (品名)	IC Test Probes
APPROVE (核准)	-	PLATE (镀层)	Seeing notes(见备注)				

THE UNMARKED TOLERANCE ARE AS BELOW :
 (未标记的公差)
 LENGTH (尺寸) ANGLE (角度)

0~6.0	±0.05mm	0. ±2.0°
>6~30	±0.10mm	0.0 ±1.0°
>30~120	±0.15mm	0.00 ±0.50°

C.C.P. (DG) CONTACT PROBES CO.,LTD.
东莞中探探针有限公司
 The information in this document is property of C.C.P company and should not be copied or reproduced in any other way, without written permission.

4

3

2

1