

4

3

∇

2

1

Please Approve this Drawing	
Date	
Signature	

REVISIONS

NO.	DESCRIPTION	ECN NO.	DATE
A.0	INITIAL RELEASE	ECN-220120611002	2012.06.11
A.1	Change 16.55 To 16.35 Change 3.55 To 3.35	ECN-220120711002	2012.07.11
A.2	Change 95±20% to 80g±20%	ECN-2201707024	2017.07.19

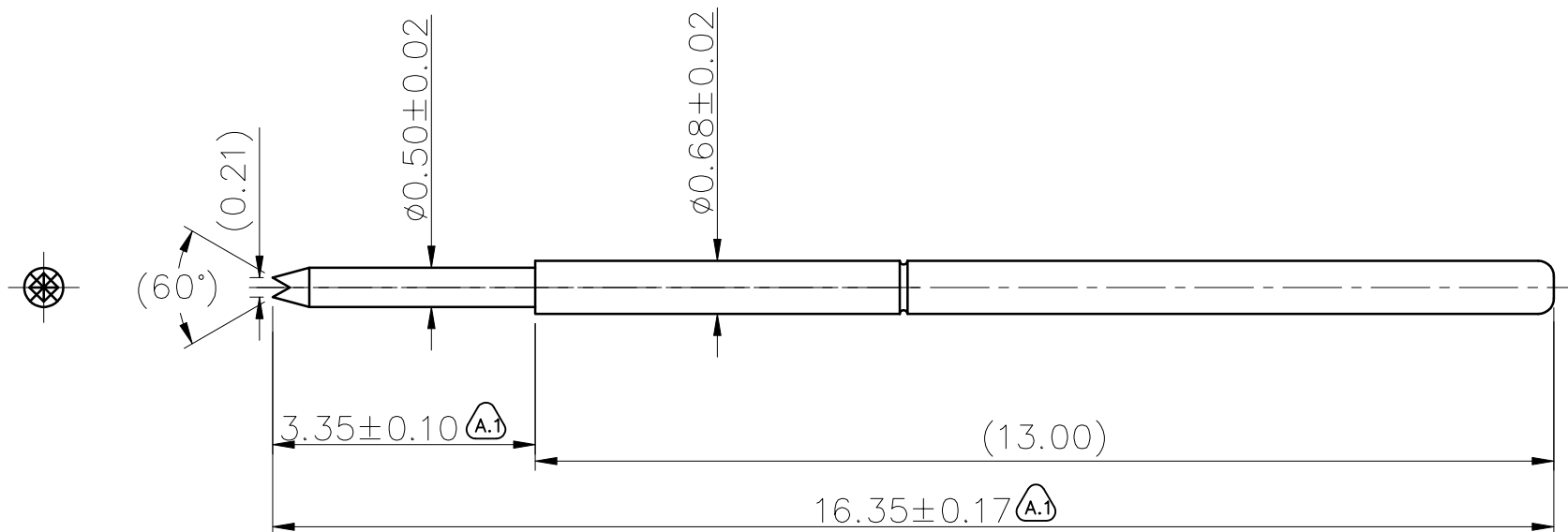

NOTE;

1.Material

Plunger: BeCu Au Plated
Barrel: PhBz Au Plated
Spring: SUS304 No Plated

2.Electrical

Rated current : 1.5A Max.
Contact resistance: 70 mohm maximum at 2/3 stroke(quiescence)

3.Mechanical

Full stroke: 3.35 mm
Spring Force :80g±20% at 2/3 stroke (A.2)
Spring force: 120g±20% at 3.35mm stroke(reference)
Durability: 100,000 cycles(minimum)

4.RoHS and HF compliant product.

DRAW (设计)	陈冀雄	SCALE (比例)	10 : 1	UNIT (单位)	mm	DRAWING NO. (图号)	P-0F1-0512
COUNTER SIGN (会签)		SHEET (页数)	1 of 1	PROJECT (视图)		MATERIAL (材质)	Seeing notes (见备注)
AUDIT (审核)		DATE (日期)	2017.07.19	VER (版次)	A.2	TITLE (品名)	Test Probe
APPROVE (核准)		PLATE (镀层)	Seeing notes(见备注)				

THE UNMARKED TOLERANCE ARE AS BELOW :

LENGTH (尺寸)		ANGLE (角度)	
0~6.0	±0.05mm	0.	±2.0°
>6~30	±0.10mm	0.0	±1.0°
>30~120	±0.15mm	0.00	±0.50°

C.C.P. (DG) CONTACT PROBES CO.,LTD.

东莞中探探针有限公司

The information in this document is property of C.C.P company and should not be copied or reproduced in any other way, without written permission.

4

3

∇

2

1