

Please Approve this Drawing

Date	
Signature	

REVISIONS (修正)			
NO. (序号)	DESCRIPTION(描述)	DCN NO.(变更号)	DATE(日期)
D.0	NEW RELEASE		2020.12.08

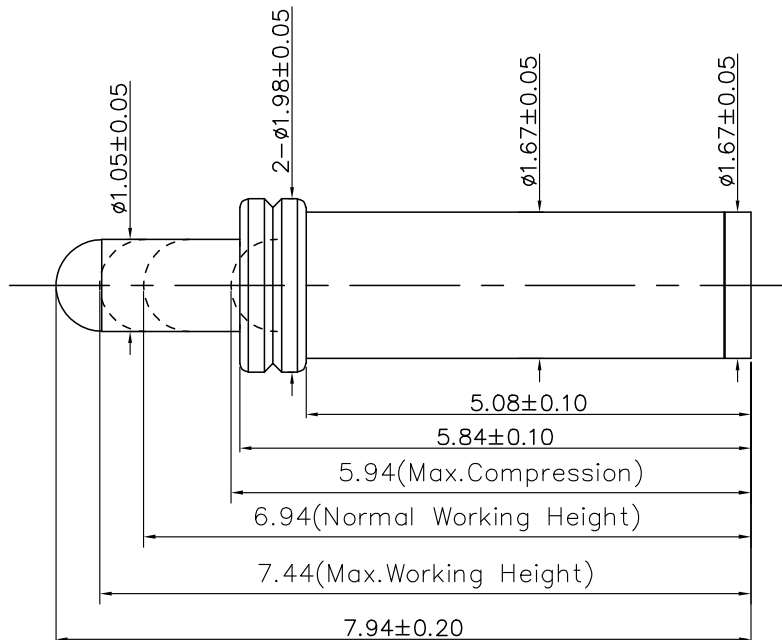

- NOTES;
- Material
Plunger: Brass
Barrel 1: QSn4-3Y
Barrel 2: Brass
Spring: SUS
 - Plating
Plunger: 20 micro-inch minimum Au over 50~120 micro-inch nickel
Barrel : 20 micro-inch minimum Au over 50~120 micro-inch nickel
 - Electrical
Rated current & voltage: DC12V; 2A,3A Peak.
Contact resistance: 50 mohm maximum at working height(quiescence)
 - Mechanical
Spring force: 60g±15g at Normal working height
Durability: 10,000 cycles(minimum)
 - Please operate the product at its indicated normal working height, to ensure a proper functioning of the product. To avoid damaging the product, do not exceed the maximum compression. Above the maximum recommended working height the spring force may vary significantly from the indicated value.
 - RoHS & HF complied product.

DRAW (设计)	龙飞常	SCALE (比例)	10 : 1	UNIT (单位)	mm	DRAWING NO. (图号)	P08824SH1
COUNTER SIGN (会签)		SHEET (页数)	1 of 1	VIEW (视图)		MATERIAL (材质)	See notes (见备注)
AUDIT (审核)		DATE (日期)	2020.12.08	VERSION (版次)	D.0	TITLE (品名)	Pogo pin
APPROVE (核准)		PLATING (镀层)	See notes(见备注)				

NOT INDICATED TOLERANCE ARE AS BELOW :
(未标记的公差)

LENGTH (尺寸)		ANGLE (角度)	
0~6.0	±0.05mm	0.0	±2.0°
>6~30	±0.10mm	0.0	±1.0°
>30~120	±0.15mm	0.00	±0.50°

C.C.P. (DG) CONTACT PROBES CO.,LTD.
东莞中探探针有限公司

The information in this document is property of C.C.P company and should not be copied or reproduced in any other way, without written permission.