

Please Approve this Drawing	
Date	
Signature	

东莞中探探针有限公司
 研发单位
 2017-12-12
 圖面請妥善保管
 版權所有翻印必究



REVISIONS (修正)			
NO. (序号)	DESCRIPTION (描述)	DCN NO. (变更号)	DATE (日期)
D.0	NEW RELEASE	DCN-201712040	2017.12.11

NOTES:

- Materials:
 - .Plunger: brass
 - .Barrel(1)&Barrel(2): brass
 - .Spring: SUS
- Plating:
 - .Plunger: 20 micro-inch minimum Au over 50~120 micro-inch nickel.
 - .Barrel(1)&Barrel(2) : 20 micro-inch minimum Au over 50~120 micro-inch nickel.
- Electrical:
 - .Rated current & voltage: DC12V, 3Amax.
 - .Contact resistance: 100 mohm maximum at working height(quiescence)
- Mechanical:
 - .Normal force: 60±20g at Normal working height
 - .Durability: 10,000 cycles(minimum)
- When the current is greater than 1A then need to increase the time delaycircuit(3 second)
- To ensure the best usage,please operate it based on the working height
 - .Based on the engineering drawings,shall not exceed the maximum allowed compression
- RoHS & HF complied product.

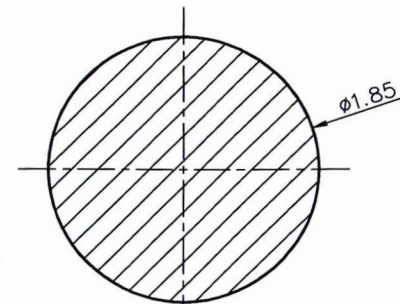
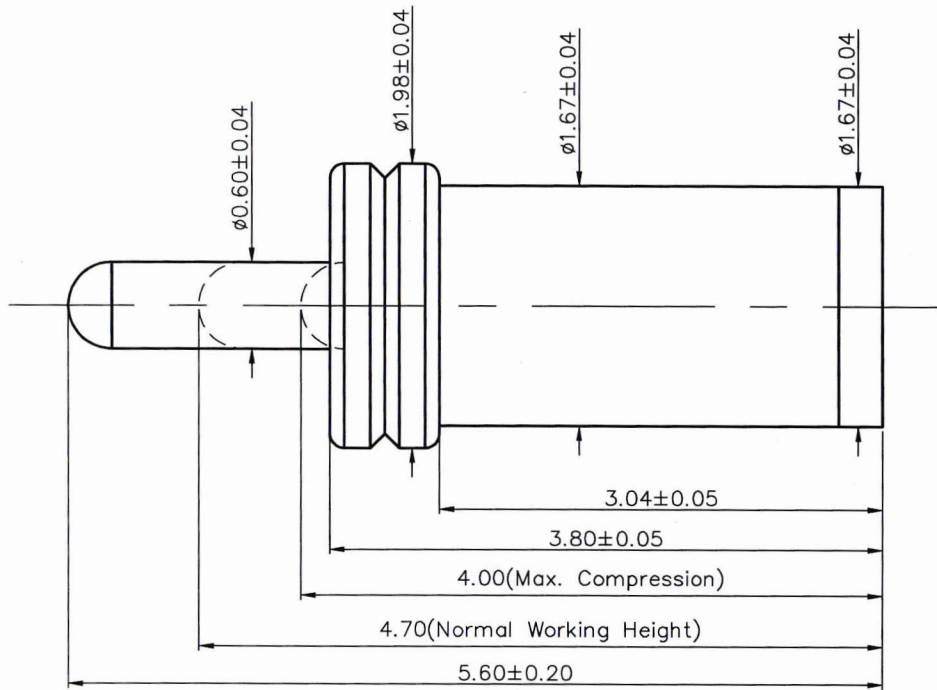

RECOMMEND PCB LAYOUT(TOP VIEW)
Layout Tolerance: ± 0.05mm

DRAW (设计)	Benson_Zhou	SCALE (比例)	10 : 1	UNIT (单位)	mm	DRAWING NO. (图号)	P6330FP03-R
COUNTER SIGN (会签)		SHEET (页数)	1 of 1	PROJECT (视图)		MATERIAL (材质)	Seeing notes (见备注)
AUDIT (审核)	<i>Handwritten signature</i>	DATE (日期)	2017.12.11	VER (版次)	D.0	TITLE (品名)	Pogo pin Conn.
APPROVE (核准)	<i>Handwritten signature</i>	PLATE (镀层)	Seeing notes(见备注)				

THE UNMARKED TOLERANCE ARE AS BELOW :

LENGTH (尺寸)		ANGLE (角度)	
0~6.0	±0.05mm	0.	±2.0°
>6~30	±0.10mm	0.0	±1.0°
>30~120	±0.15mm	0.00	±0.50°

C.C.P. (DG) CONTACT PROBES CO.,LTD.
 东莞中探探针有限公司
 The information in this document is property of C.C.P company and should not be copied or reproduced in any other way, without written permission.