

Please Approve this Drawing

Date	
Signature	

REVISIONS		
LTR	DESCRIPTION	ECN No.
	INITIAL RELEASE	ECN-10705013
①		
②		

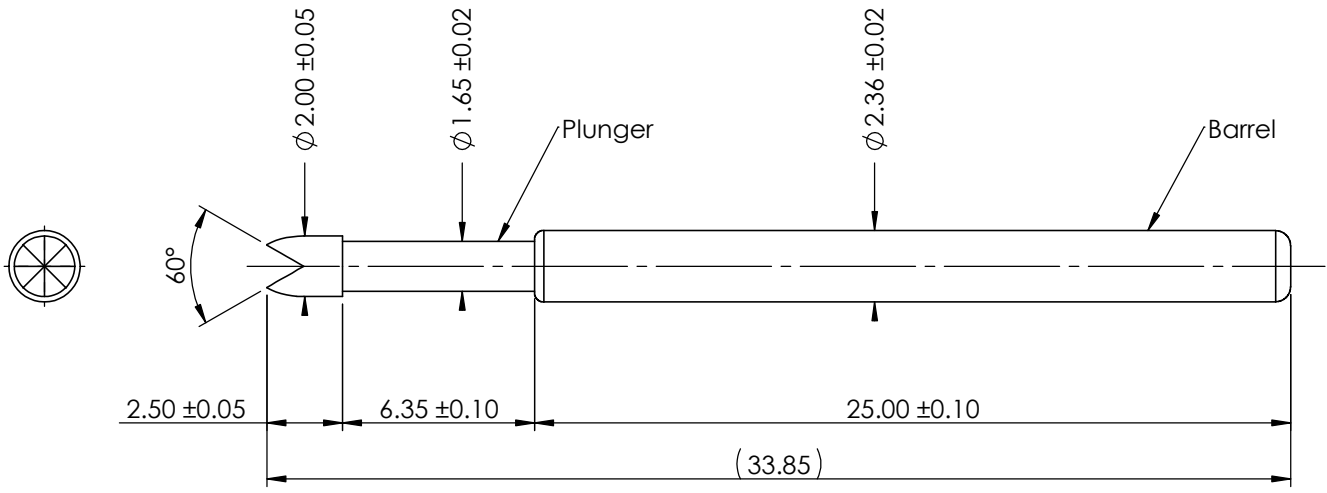
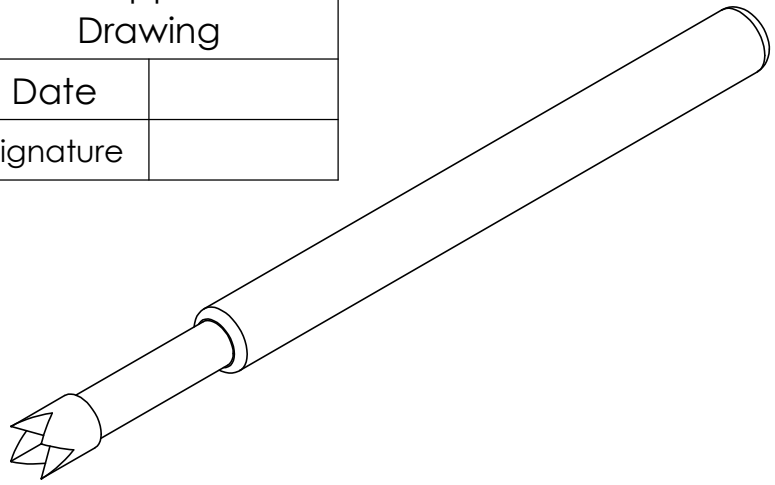

Notes :

- Materials and Finishes
 - Plunger : BeCu alloy with gold plating
 - Barrel : Brass alloy with gold plating
 - Spring : SUS304 with not plating
- Mechanical
 - Full Stroke : 6.35 mm
 - Spring force : 230 g \pm 15% at 4.2mm stroke.
- Durability :
 - Mechanical life 200k cycles(minimum) at 4.2mm stroke.

Drawn	Karin_C	Date	2018/5/24
Checked	Chuna_W	Date	2018/5/24
Approved	Allan_L	Date	2018/5/24
Scale	4:1	Unit	mm

DIMENSIONS ARE IN MILLIMETERS
TOLERANCES ARE:
DECIMALS ANGLES
X. ± .25 ± 5.0°
XX ± .15 ± 3.0°
X.XX ± .10 ± 2.0°

THE INFORMATION AND DESIGN DISCLOSED HEREIN WAS ORIGINATED BY AND IS THE PROPERTY OF C.C.P. CONTACT PROBES CO.,LTD. C.C.P. CONTACT PROBES CO.,LTD. RESERVES ALL PATENT, PROPRIETARY DESIGN, MANUFACTURING, REPRODUCTION, USE AND SALES RIGHTS THEREOF, AND TO ANY ARTICLE DISCLOSED HEREIN EXCEPT TO THE EXTENT RIGHTS ARE EXPRESSLY GRANTED TO OTHERS. THE FOREGOING DOES NOT APPLY TO VENDOR PROPRIETARY RIGHTS.

中國探針股份有限公司
C. C. P. CONTACT PROBES CO., LTD.

TITLE: Probes

Size: A4

Drawing No. S-11F1-2523Z

Rev. A0