

4

3

2

1

REVISIONS (修正)			
NO. (序号)	DESCRIPTION(描述)	DCN NO.(变更号)	DATE(日期)
D.0	NEW RELEASE	DCN-202112114	2021.12.17

Please Approve this Drawing	
Date	
Signature	

东莞中探探针有限公司  
研发单位

2021-12-22

图面请妥善保管  
版权所有翻印必究

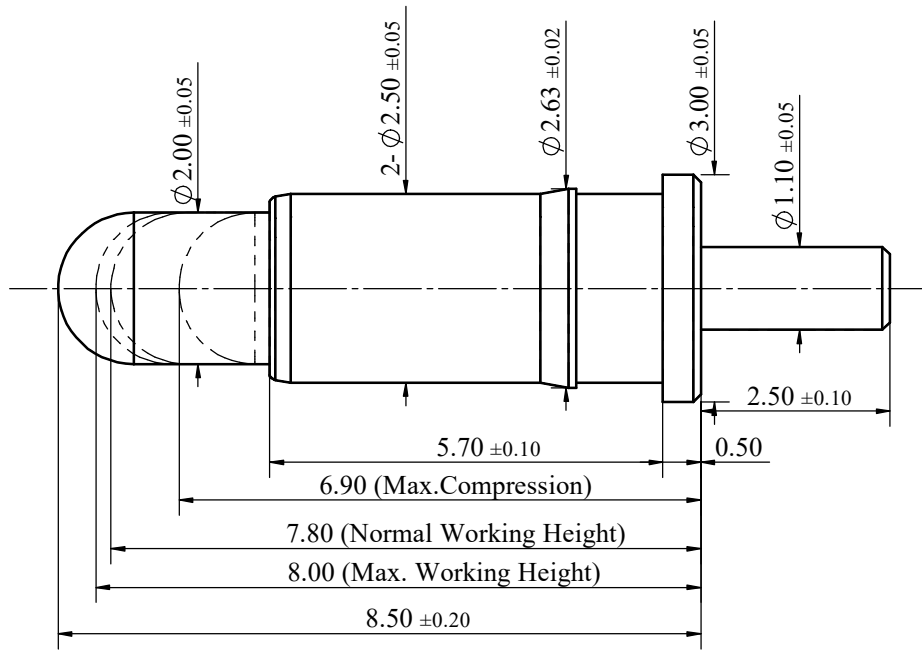

**NOTES:**

- 1.Material**  
Plunger: Brass  
Barrel: Brass  
Spring: SUS
- 2.Plating**  
Plunger: 10 micro-inch minimum Au over 50~120 micro-inch nickel  
Barrel : 10 micro-inch minimum Au over 50~120 micro-inch nickel
- 3.Electrical**  
Rated current & voltage: DC12V; 1A.  
Contact resistance: 50 mohm maximum at working height (quiescence)
- 4.Mechanical**  
Spring force: 50g±15g at Normal working height  
Durability: 200,000 cycles (minimum)
- 5.Please operate the product at its indicated normal working height to ensure a proper function of the product. To avoid damaging the product, do not exceed the maximum compression.**
- 6.RoHS & HF compliant product.**



DRAW (设计)	龙飞常	SCALE (比例)	10:1	UNIT (单位)	mm	DRAWING NO. (图号)	P09399PH1
COUNTER SIGN (会签)	N/A	SHEET (页数)	1 of 1	VIEW (视图)		MATERIAL (材质)	N/A
AUDIT (审核)	肖大庭	DATE (日期)	2021/12/20	VERSION (版次)	D.0	TITLE (品名)	Pogo pin Conn.
APPROVE (核准)	肖大庭	PLATING (镀层)	See Notes (见备注)				

NOT INDICATED TOLERANCES ARE AS BELOW :  
(未标记的公差)  
LENGTH (尺寸) ANGLE (角度)

0~6.0	±0.05mm	0.0	±2.0°
>6~30	±0.10mm	0.0	±1.0°
>30~120	±0.15mm	0.00	±0.50°

**C.C.P. (DG) CONTACT PROBES CO.,LTD.**  
**东莞中探探针有限公司**

The information in this document is property of C.C.P company and should not be copied or reproduced in any other way, without written permission.

4

3

2

1